



VACUUM SEALER SE-308

Tabletop model. 8 m³/h.



FOOD PRESERVATION AND SOUS-VIDE
VACUUM PACKING MACHINES · SENSOR LINE



OPTIONAL

- Vacuum packing bags.
- External vacuum kit for Vac-Norm, containers and accessories.
- Support for liquid packaging.
- Additional filling plates.

SPECIFICATIONS

Pump capacity: 8 m³/h
 Pump capacity (60 Hz): 10 m³/h
 Bar length: 320 mm
 Total loading: 450 W
 Vacuum pressure (maximum): 2 mbar

Internal dimensions

- ✓ Width: 330 mm
- ✓ Depth: 360 mm
- ✓ Height: 155 mm

External dimensions (W x D x H)

- ✓ Width: 384 mm
- ✓ Depth: 465 mm
- ✓ Height: 405 mm

Net weight: 36.1 kg

Noise level (1m.): 75 dB(A)
 Background noise: 32 dB(A)

Crated dimensions

540 x 478 x 465 mm
 Gross weight: 43.1 kg

AVAILABLE MODELS

1141083 SE-308 230/50-60/1

* Ask for special versions availability

SALES DESCRIPTION

8 m³/h Busch vacuum pump.
 Vacuum controlled by sensor.

- ✓ Powered by Busch.
- ✓ Vacuum controlled by sensor.
- ✓ Vacuum PLUS.
- ✓ Digital keyboard.
- ✓ Control panel equipped with display indicating the exact vacuum percentage.
- ✓ "Pause" button to marinate food.
- ✓ Safe liquid packing thanks to sensor control.
- ✓ Double seal.
- ✓ Cordless sealing bar.
- ✓ Bag-sealing programme.
- ✓ Pulse-controlled decompression.
- ✓ Vac-Norm ready with Automatic decompression.
- ✓ Stainless steel body and chamber. Deep-drawn chamber.
- ✓ Damped transparent lid.
- ✓ Dry-oil programme for drying the pump.
- ✓ Working hours counter for oil changes.
- ✓ Safety system with protection against vacuum failure.
- ✓ NSF-listed model.

INCLUDES

- ✓ Sensor controls.
- ✓ Busch pump.
- ✓ Up to 10 seconds of extra vacuum pull.
- ✓ NSF approved.
- ✓ Soft air function.
- ✓ Clear methacrylate lid.
- ✓ Dry oil cycle.
- ✓ Filling plate.



product sheet
updated 13/05/2024



VACUUM SEALER SE-308

Tabletop model. 8 m³/h.



FOOD PRESERVATION AND SOUS-VIDE
VACUUM PACKING MACHINES · SENSOR LINE

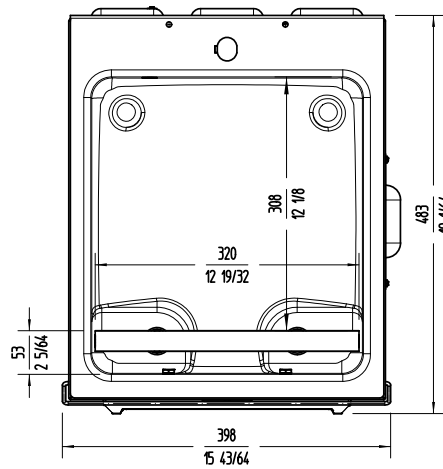
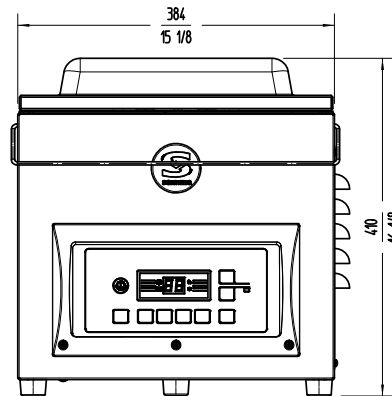
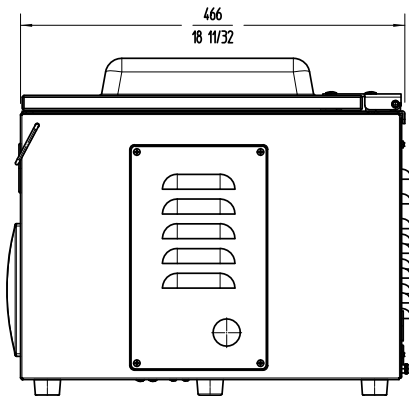

 **sammic** | www.sammic.com
Food Service Equipment Manufacturer

Polígono Basarte, 1. phone +34 943 15 72 36
20720 Azkoitia, Spain sales@sammic.com



Project	Date
Item	Qty
Approved	

product sheet
updated 13/05/2024